

Description

The MOSFET provide the best combination of fast switching, low on-resistance and cost-effectiveness.

MOSFET Product Summary		
V _{DS} (V)	R _{DS(on)} (Ω)	I _D (A)
20	0.2@ V _{GS} =4.5V	1
	0.25@ V _{GS} =2.5V	
	0.31@ V _{GS} =1.8V	
ESD	HBM	MM
	Pass 500V	Pass 100V

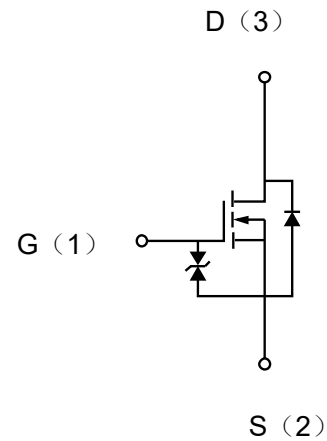

Absolute maximum rating@25°C

Parameter	Symbol	Value	Units
Drain-Source Voltage	V _{DS}	20	V
Gate-Source Voltage	V _{GS}	±10	V
Continuous Drain Current(T _J =150°C)	Continuous	I _D	A
	Pulsed	I _{DP}	
Total power dissipation	P _D	140	mW
Channel temperature	T _{CH}	150	°C
Range of storage temperature	T _{STG}	-55 to +150	°C

Thermal resistance

Parameter	Symbol	Limits	Units
Channel to ambient	R _{th(ch-a)}	800	°C/W

Ordering information

Device	Package	Shipping
TCS1275-C	SOT-723 (Pb-Free)	10000 / Tape & Reel