

BV_{DSS}	R_{DS(ON)}	I_D
30V	1.4mΩ	150A

Features

- 1、 Ultra Low R_{DS(on)}
- 2、 Excellent Gate Charge*R_{DS(ON)} Product(FOM)
- 3、 Pb-Free Halogen Free and RoHS compliant
- 4、 Improved dv/dt capability
- 5、 100% Avalanche Tested

Applications

- 1、 DC/DC Converter
- 2、 Ideal for high-frequency switching and synchronous rectification

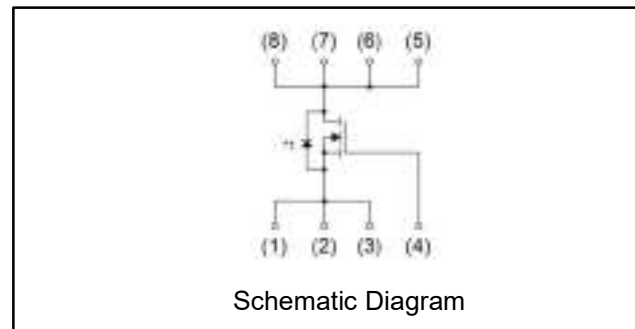
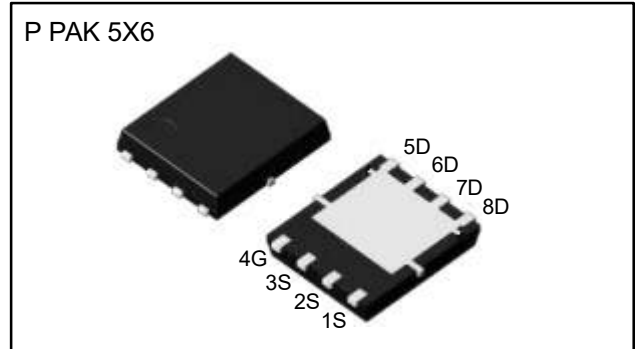

Packaging Specifications

Packing	Marking	Reel Size	Tape width	Basic ordering unit	Taping code
Embossed Tape		Ø330mm	12mm	5000	

Absolute Maximum Ratings (T_C=25°C unless otherwise noted)

Symbol	Parameter	Value	Unit
V _{DS}	Drain-Source Voltage (V _{GS} =0V)	30	V
V _{GS}	Gate-Source Voltage (V _{GS} =0V,static)	±20	V
I _D	Continuous Drain Current (T _C =25°C)	150	A
	Continuous Drain Current (T _C =100°C)	120	A
I _{DM} Note1	Pulesd Drain Current	350	A
I _{AS}	Avalanche Current	150	A
E _{AS} Note5	Single Pulsed Avalanche Energy	635	mJ
P _D	Maximum Power Dissipation (T _C =25°C)	110	W
	Derating Factor	0.68	W/°C
T _J ,T _{STG}	Operating,Storage Temperature Range	-55~150	°C

Thermal Characteristics

Symbol	Parameter	Max.	Unit
R _{θJA} Note2	Thermal Resistance,Junction-to-Ambient	-	°C/ W
R _{θJC}	Thermal Resistance,Junction-to-Case	1.47	°C/ W