

FEATURES

- High Efficiency: Up to 95% (@3.3V_{OUT})
- 2.3MHz Switching Frequency Operation
- Up to 2A Output Current
- 2.5V to 5.5V Input Voltage Range
- Output Voltage as Low as 0.6V
- PFM Mode for High Efficiency in Light Load
- 100% Duty Cycle in Dropout Operation
- Low Quiescent Current: 40μA
- Short Hiccup Protection
- Thermal Fault Protection
- Inrush Current Limit and Soft Start
- Input over voltage protection (OVP)
- <1μA Shutdown Current
- DFN1.6x1.6-6 Package

APPLICATIONS

- Set Top Box
- Wireless and DSL Modems
- Portable Instruments
- Digital Still and Video Cameras
- PC Cards

GENERAL DESCRIPTION

The TCS4021 is a 2.3MHz switching frequency, current mode step-down converter. It is ideal for portable equipment requiring very high current up to 2A from single-cell Lithium-ion batteries or other input source from 2.5V to 5.5V input voltage and the output voltage can be regulated as low as 0.6V. The TCS4021 also can run at 100% duty cycle for low dropout operation, extending battery life in portable systems while light load operation provides very low output ripple for noise sensitive applications. The high switching frequency minimizes the size of external components while keeping switching losses low. The internal slope compensation setting allows the device to operate with smaller inductor values to optimize size and provide efficient operation. The TCS4021 adopts small size DFN1.6x1.6-6 package.

This device offers two operation modes, PWM control and PFM Mode switching control, which allows a high efficiency over the wider range of the load.

TYPICAL APPLICATION

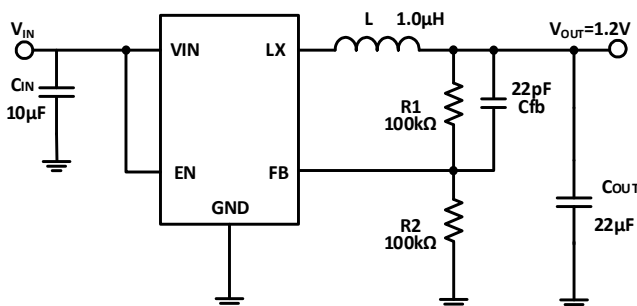

Figure 1. Basic Application Circuit

Efficiency

V_{OUT}=1.2V, L=1.0μH, T_A=25°C, I_o=10mA to 2A

