

FEATURES

- Compatible I²C Interface Up to 3.4MHz
- Input Voltage Range :2.7V~5.5V
- Up to 5A Output Current
- Mode Selection Between PFM and PWM at Light Load
- Typical 50μA Quiescent Current in Light Load PFM Mode
- 2.1MHz Switching Frequency
- Integrated Soft-Start
- Input UVLO and OVP
- Build in Thermal Shutdown and OCP
- 0.25μH Inductor Support
- I²C address: 0x82
- Compact WLCSP-20 Package

APPLICATIONS

- Smart Phones
- DSP or CPUs Processors
- Tablet, MID

APPLICATIONS

GENERAL DESCRIPTION

TCS4838 is an I²C Programmable, high efficiency, 2.1MHz, Synchronous Buck converter that operates in wide input voltage range from 2.7V to 5.5V. The output Voltage could be programmed from 0.7125V to 1.5V. Very low standby current ensure high efficiency in light load PFM mode. The forced PWM mode could be set to avoid application problems caused by low switching frequency. A COT(Constant On-Time) structure is adaptive to achieve the fixed switching frequency and fast load transient response. TCS4838 provides up to 5A output current with Integrated 28mΩ(high side) and 18mΩ(low side) power switch. TCS4838 also implement an internal soft-start and cycle-by-cycle overcurrent protection function. In addition, the input UVLO and OVP protection, Thermal shutdown protection.

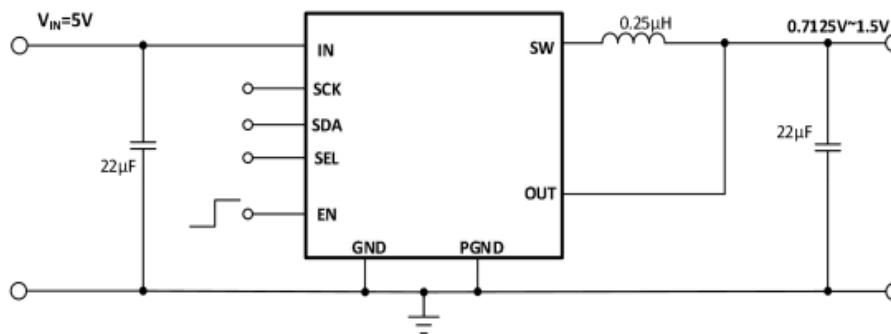

Figure 1. Basic Application Circuit

ABSOLUTE MAXIMUM RATINGS (Note 1)

Parameter	Min	Max	Unit
All Voltage Range	-0.3	6.5	V
Junction Temperature (Note2)	-40	150	°C
Storage Temperature	-65	150	°C
Junction-to-ambient Thermal Resistance	-	38	°C/W
Junction-to-case Thermal Resistance	-	9	°C/W
Power Dissipation	-	2.6	W